

Back of Cab



PHILIPS

WE MAKE PRODUCTS THAT MAKE A DIFFERENCE[®]

The image shows a collection of Phillips Trackers cables and connectors. On the left, two black cables with 'PHILLIPS TRACKERS' printed on them are suspended by metal springs from a white metal structure. Below them, a coiled cable with red, blue, and green braided sections is visible. On the right, a green cable with a grey connector is plugged into a blue connector on a white panel. Below that, a red cable with a grey connector is plugged into a red connector on the same panel. The background is a white metal surface with a perforated metal grate in the foreground.

Since 1928, the Phillips family has taken steps to revolutionize the commercial vehicle industry by offering innovative solutions that exceed industry standards. We have a deep understanding of industry needs, and we take a thoughtful approach to developing timeless, quality products. We think about the details so that you don't have to.

Our team deeply values the relationships we have built with our customers. As we continue to grow and innovate, our core values of quality and customer-centricity remain unwavering.

The Phillips family is excited to deliver products that go beyond your expectations.

We look forward to the opportunity and privilege of serving you and contributing to the continued success of your business.

The Phillips Family

THE DIFFERENCE

Learn How Phillips' Solutions Provide Unparalleled Safeguarding Against Corrosion.

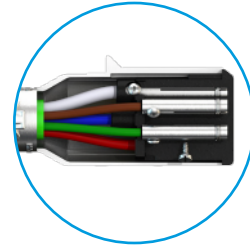

2

POWER + AIR KITS

All-in-One Complete HEAVY-DUTY Back-of-Cab System Solutions.



4

ELECTRICAL

3-IN-1 Assemblies, 7-Way Electrical Assemblies, ISO Assemblies, Sockets, Plugs, Electrical Connector Repair Accessories



6

LIFTGATE & TARP SYSTEMS

M2 Charge Kit, WEATHER-TITE™ M2, Dual Pole, Single Pole, Vertical Dual Pole, Dual Pole to Single Pole, Sockets, Plugs, Liftgate Connector Repair Accessories



16

AIR & GLADHANDS

Nylon Coiled Assemblies, Rubber Air Lines, Air Accessories, Straight Mount Gladhands, Specialty Gladhands, Replacement Gladhand Seals



24

CABLE SUPPORT

Tracker Spring Kit Products, X-TEND® Tracker Bar Extension, Hose Holders, Pogo Sticks, Replacement Springs, STOW-A-WAY™, Spiral Wrap, Hose Separators, Carabiner Clips, Cable Ties



32

The Difference

UPTIME starts here

The best protection from magnesium chloride, calcium chloride, and road salt corrosion

A look inside the QCP™ - Quick-Connect Plug

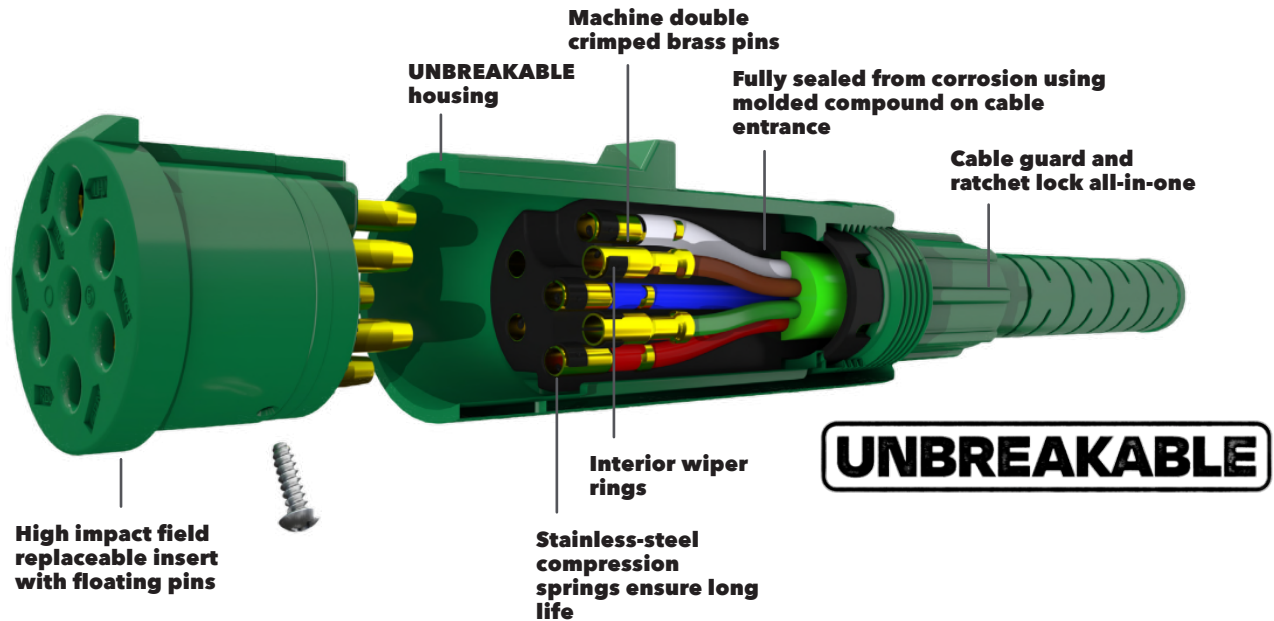

Field Serviceable Insert

Corrosion getting in the insert? Simply remove one screw, pop off the old insert, replace with your spare and off you go. Takes only seconds to replace.



1. Unscrew cable guard
2. Remove single screw
3. Push cable forward to slide out insert
4. Pull off old insert and plug in new (16-125)
5. Push unit back into position
6. Insert and attach screw
7. Twist cable guard tight into locking position



SCAN HERE FOR MORE INFORMATION



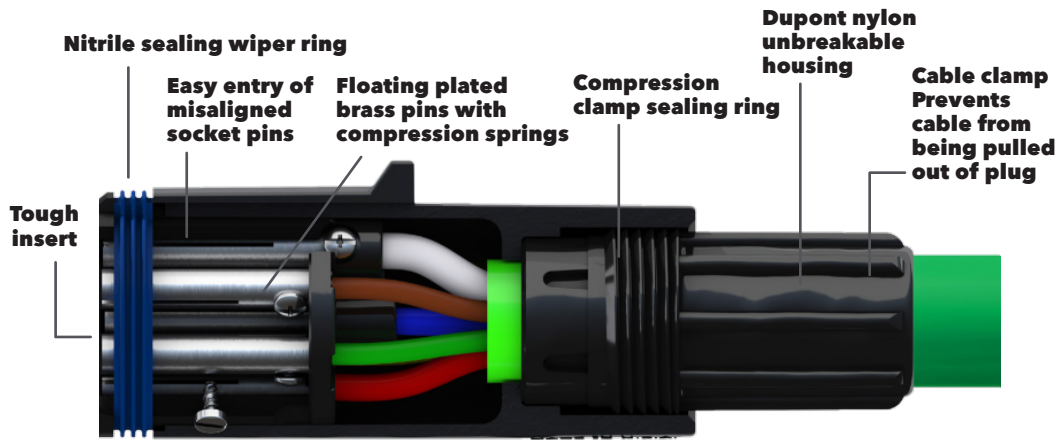

16-730
WEATHER-TITE™



SCAN HERE FOR MORE INFORMATION

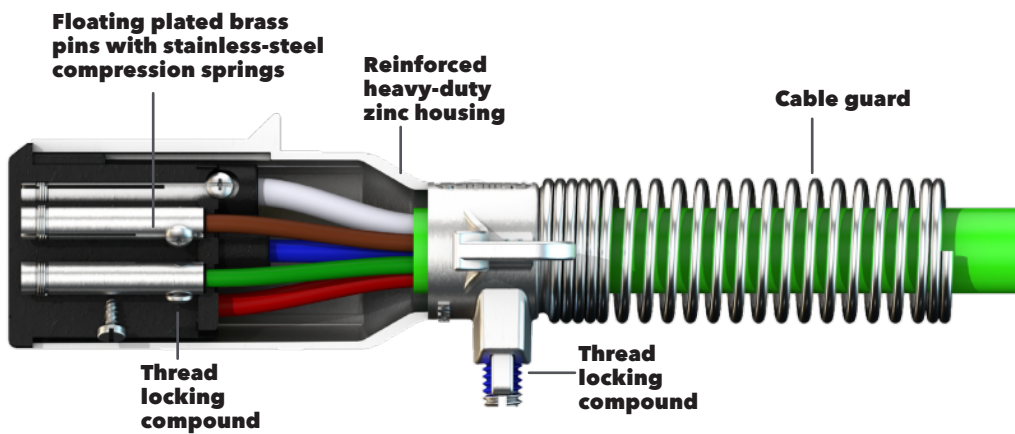

15-730
ZINC DIE-CAST



SCAN HERE FOR MORE INFORMATION

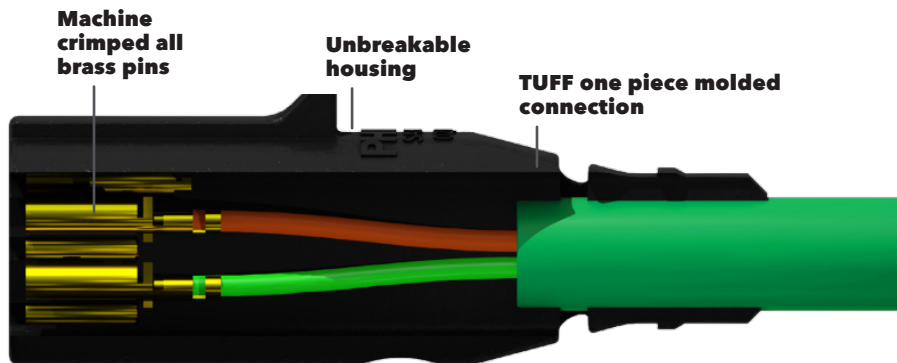

M7



SCAN HERE FOR MORE INFORMATION

STA-CONNECT ANTI-THEFT

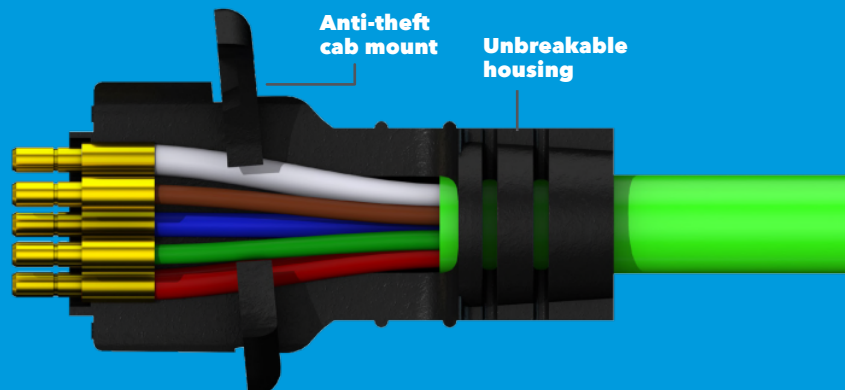

QCMS2™

The QCMS2™ replaces the socket



POWER + AIR KITS

COMPLETE heavy-duty back-of-cab system



12' 30-215429 *STD PKG: 1*

15' 30-217429 *STD PKG: 1*



The QWIK-CHANGE™ PAK delivers our best products with a single part number housed in a box for easier inventory management, invoicing, and convenient sourcing for retail and installation.

COMPONENTS of the QWIK-CHANGE™ PAK

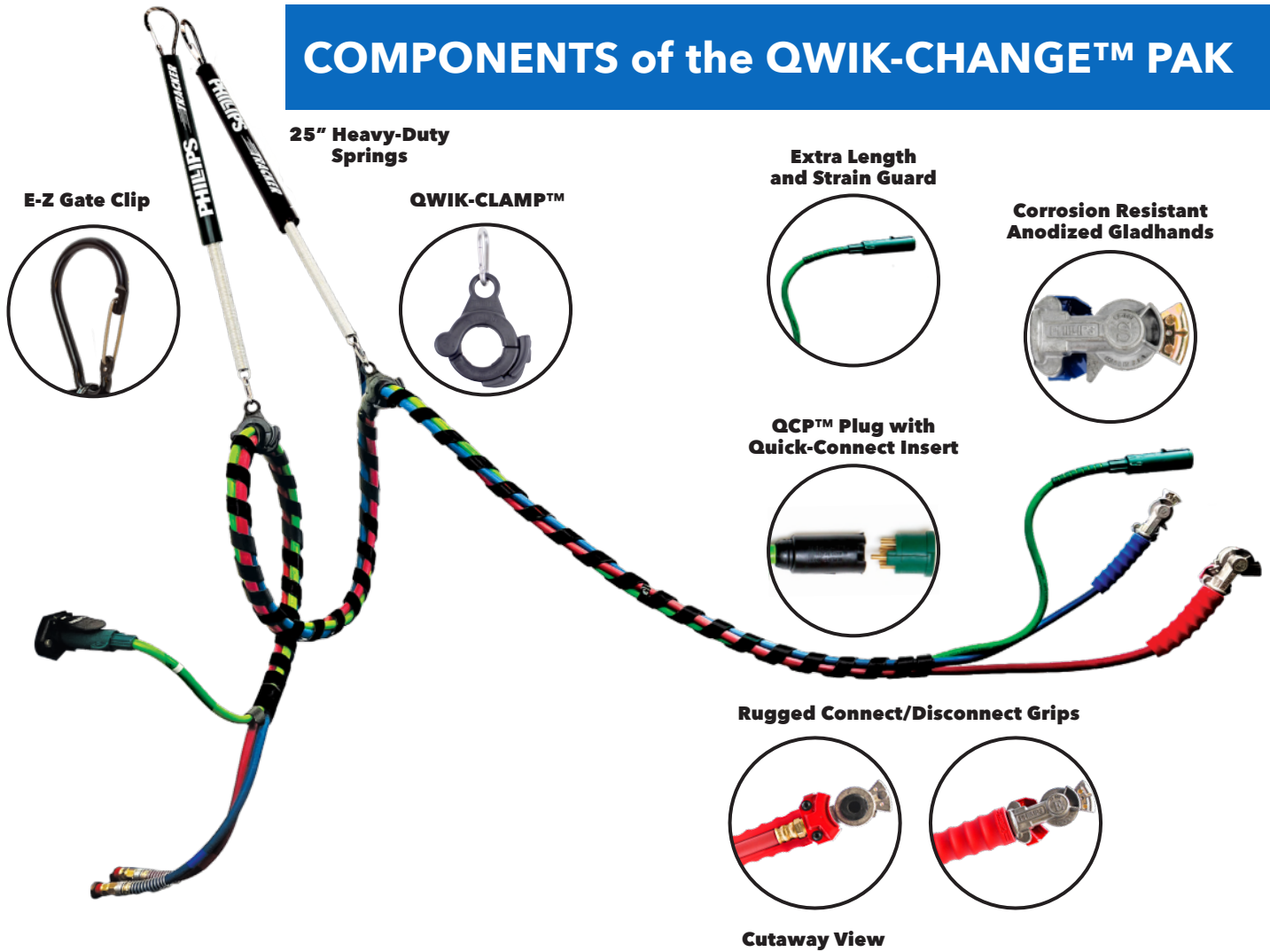

Setting THE OEM STANDARD for a back-of-cab system



STANDARD OEM **PAK** POWER+AIR KIT

12' 30-245029 *STD PKG: 1*

15' 30-247029 *STD PKG: 1*

The STANDARD OEM PAK is designed with everything you need to get back on the road.

COMPONENTS of the STANDARD OEM PAK

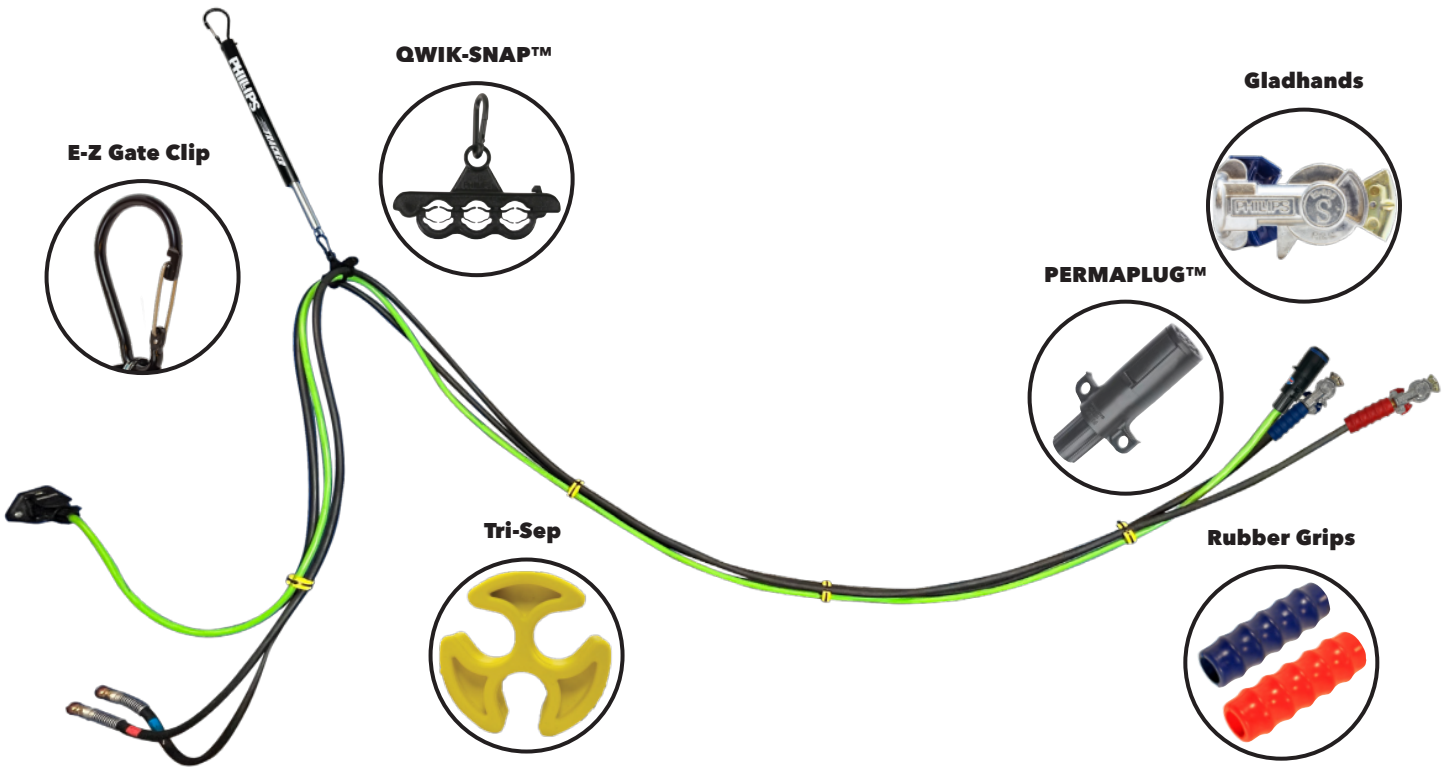

3-IN-1 ASSEMBLIES

Phillips 3-IN-1 products meet the highest quality standards and provide a wide range of options to fit your unique needs. Our premium plugs keep your connections corrosion-free. We are committed to excellence with products that last.

ALL

- Spiral wrapped for a clean organized look
- Crack, kink, abrasion, and weather resistant

ELECTRICAL

- Spring-wrapped compression brass contact pins with exception of QCMS2™ and M7
- Chemical resistant

AIR

- Colored rubber grips for easy coupling/uncoupling
- Tractor end includes swivel fitting for easy installation
- Color coded red and blue, with exception to M7 assemblies which are black
- Flexible to -40°F

QCP™ (Quick-Connect Plug) STD PKG: 1

Our premium QCP 3-N-1 assemblies come with a strain relief cable guard & have a 9" longer cable to reduce strain and reinforced stability at the back of the plug



- 30-2154 12' 3-IN-1 with QCP™
- 30-2174 15' 3-IN-1 with QCP™

- Plug-in replaceable insert
- Cartridge is field replaceable in seconds
- Trailer-side 7-way with extended cable guard
- Includes 17-181 QWIK-CLAMP™
- Extended cable length to relieve stress on plug & socket



UNBREAKABLE

QCMS2™ STA-DRY® STD PKG: 1

Our premium QCP 3-N-1 assemblies come with a strain relief cable guard & have a 9" longer cable to reduce strain and reinforced stability at the back of the plug



- 30-2155 12' 3-IN-1 with QCMS2™ and QCP™
- 30-2175 15' 3-IN-1 with QCMS2™ and QCP™

- Semi-permanent tractor-side connection
- QCMS2™ bolts into tractor socket making watertight connection
- Aids in anti-theft protection
- Trailer-side QCP™ connection with cable guard and extended lead length for reduced tension
- Includes 17-181 QWIK-CLAMP™
- Extended cable length to relieve stress on plug & socket

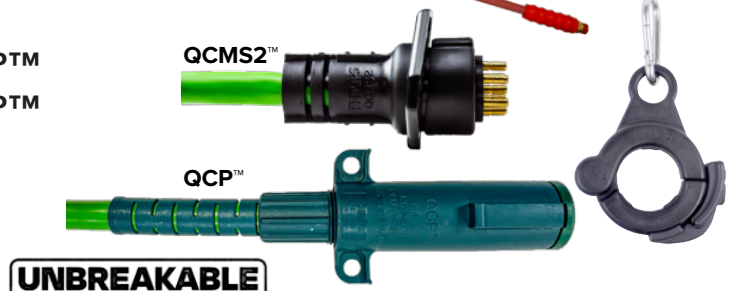

UNBREAKABLE

3-IN-1 ASSEMBLIES

16-730 Plug WEATHER-TITE™ STD PKG: 1



30-2150 12' 3-IN-1 with WEATHER-TITE™ plugs

30-2170 15' 3-IN-1 with WEATHER-TITE™ plugs

- WEATHER-TITE™ blue nitrile ring corrosion blocker
- Includes 5-5018 clamp



UNBREAKABLE

15-730 Zinc Die-Cast Plug STD PKG: 1



30-2151 12' 3-IN-1 with zinc die-cast plugs

30-2171 15' 3-IN-1 with zinc die-cast plugs

- Zinc die-cast plugs provide strength and durability
- Includes 5-5018 clamp



M7 (Molded 7-Way) Plug STD PKG: 1



30-1157 12' 3-IN-1 with M7 plugs

30-1177 15' 3-IN-1 with M7 plugs

- Unbreakable housing
- One-piece - completely molded to the cable
- Includes 5-5018 clamp



UNBREAKABLE

7-WAY ELECTRICAL ASSEMBLIES





Our award-winning electrical assemblies are heavy-duty and easy to use - keeping tractor and trailer safely connected, and preventing unscheduled downtime and costly CSA violations. Our assemblies are built to last - featuring unbreakable, non-corrosive housings and quick-connect components to lock out harmful moisture and chemicals.

QCP™ Assemblies STD PKG: 5

ABS cable, unbreakable Super-Tuff nylon 66 housing with Quick-Connect replaceable 16-125 7-way cartridge



| UNBREAKABLE | LECTRACOIL™ | PERMACOIL™ | LECTRAFLEX™ |
|----------------------|--------------------|-------------------|--------------------|
| 12' | 30-9324 | 30-4324 | 30-2054 |
| 15' | 30-9624 | 30-4624 | 30-2074 |
| 15', 48" LEAD | 30-9924 | 30-4924 | - |



| | | |
|---|--|---|
|  -82°F (-63°C) • 195°F (91°C) EXCELLENT RECOILABILITY  |  -87°F (-63°C) • 150°F (66°C) GOOD RECOILABILITY  |  -40°F (-40°C) • 150°F (66°C) |
|---|--|---|

QCMS2™ Assemblies STD PKG: 5

ABS cable, anti-theft, anti-corrosive, semi-permanent cab attachment



| UNBREAKABLE | LECTRACOIL™ | LECTRAFLEX™ |
|----------------------|--------------------|--------------------|
| 12' | 30-9334 | 30-2055 |
| 15' | 30-9634 | 30-2075 |
| 15', 48" LEAD | 30-9934 | - |

| | |
|---|---|
|  -82°F (-63°C) • 195°F (91°C) EXCELLENT RECOILABILITY  |  -40°F (-40°C) • 150°F (66°C) |
|---|---|





7-WAY ELECTRICAL ASSEMBLIES

16-730 Assemblies STD PKG: 5

ABS cable, WEATHER-TITE™ blue nitrile ring corrosion blocker



| UNBREAKABLE | LECTRACOIL™ | PERMACOIL™ | LECTRAFLEX™ |
|----------------------|--------------------|-------------------|--------------------|
| 12' | 30-9320 | 30-4320 | 30-2050 |
| 15' | 30-9620 | 30-4620 | 30-2070 |
| 15', 48" LEAD | 30-9920 | 30-4920 | - |



| | | |
|--|---|--|
|  -82°F (-63°C) • 195°F (91°C) EXCELLENT RECOILABILITY  |  -87°F (-63°C) • 150°F (66°C) GOOD RECOILABILITY  |  -40°F (-40°C) • 150°F (66°C) |
|--|---|--|

M7 (Molded 7-Way) Assemblies STD PKG: 5

ABS cable with one-piece solid dura-sealed connector



| UNBREAKABLE | PERMACOIL™ | LECTRAFLEX™ |
|----------------------|-------------------|--------------------|
| 12' | 30-4327 | 30-2057 |
| 15' | 30-4627 | 30-2077 |
| 15', 48" LEAD | 30-4927 | - |

| | |
|--|---|
|  -87°F (-63°C) • 150°F (66°C) GOOD RECOILABILITY  |  -40°F (-40°C) • 150°F (66°C) |
|--|---|

7-WAY ELECTRICAL ASSEMBLIES

15-730 Zinc Die Cast Plug STD PKG: 5

ABS cable, enlarged finger grips (for easy disconnecting), front ABS bumper, & 2.5" interior for easy wiring cross over



| | LECTRACOIL™ | PERMACOIL™ | LECTRAFLEX™ |
|----------------------|----------------|----------------|----------------|
| 12' | 30-9321 | 30-4321 | 30-2051 |
| 15' | 30-9621 | 30-4621 | 30-2071 |
| 15', 48" LEAD | 30-9921 | 30-4921 | - |

| | | |
|---|--|--------------------------------------|
| -82°F (-63°C) • 195°F (91°C) EXCELLENT RECOILABILITY | -87°F (-63°C) • 150°F (66°C) GOOD RECOILABILITY | -40°F (-40°C) • 150°F (66°C) |
|---|--|--------------------------------------|

ISO - Zinc Die-Cast Plug ISO 3731 STD PKG: 5

ISO cables with 15-830 heavy-duty zinc die-cast ISO connectors



| | ISOCOIL™ | ISOFLEX™ |
|----------------------|----------------|----------------|
| 12' | 31-9323 | 31-2053 |
| 15' | 31-9623 | 31-2073 |
| 15', 48" LEAD | 31-9923 | - |

| | |
|---|--------------------------------------|
| -82°F (-63°C) • 195°F (91°C) EXCELLENT RECOILABILITY | -40°F (-40°C) • 150°F (66°C) |
|---|--------------------------------------|

16-724 QWIK-CONNECT SYSTEM

Our unbreakable, non-corrosive socket housing is completely sealed to keep moisture and contaminants out of your electrical system. The boot is designed for front and rear entry mounting and forms a watertight seal when mated to the socket. Easy splicing into your current cab or trailer wiring system completes the installation. The socket, 16-724 is standard in most truck cabs - standardizing your inventory.

STA-DRY® QCS2® System

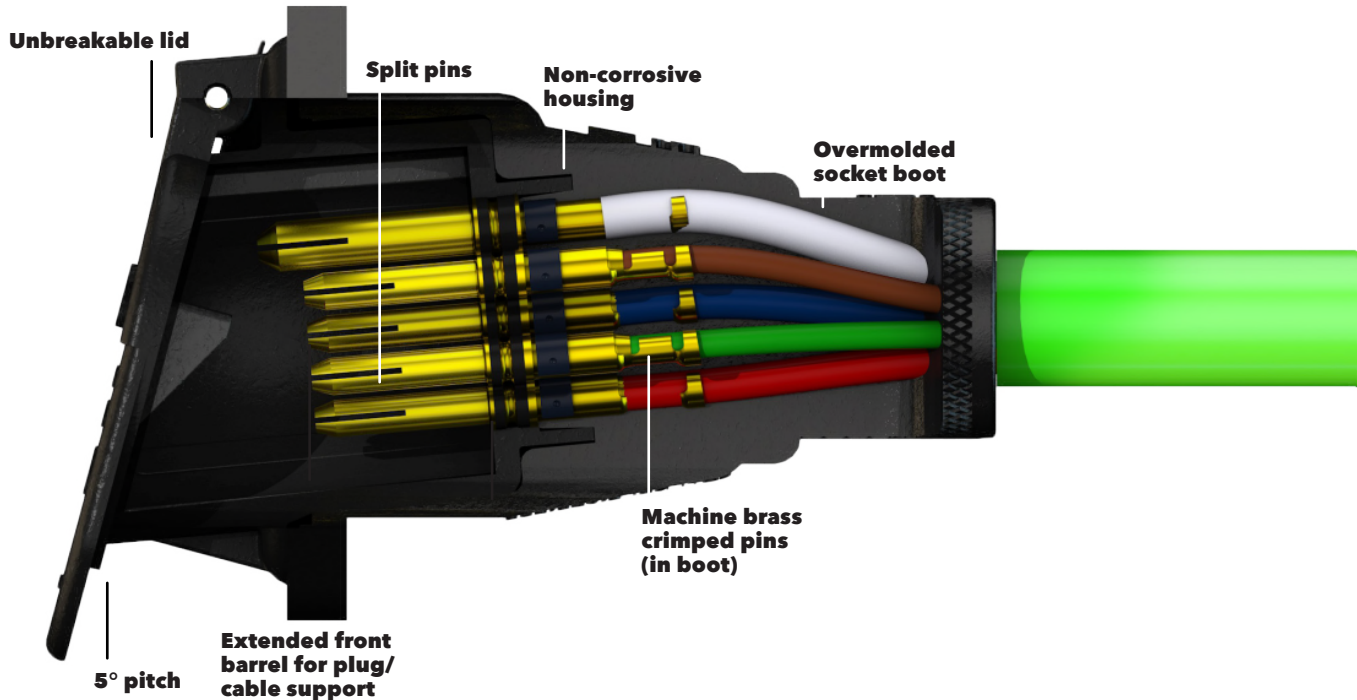

16-724 7-Way QCS2® System



16-7403

Straight back, 48" cable, includes 16-724 STA-DRY® socket

STD PKG: 1

16-7423-048

6 o'clock, 48", includes 16-724 STA-DRY® socket

STD PKG: 1

16-724

QCS2® replacement socket

STD PKG: 25

- For use with standard ABS wiring systems
- The boot is designed for front and rear installation and standard on most OEM trucks

7-WAY & ISO SOCKETS

STA-DRY® Sockets *STD PKG: 25*

Phillips premium STA-DRY® sockets have an unbreakable housing, and are completely sealed - combating corrosion and increasing uptime. 7-way sockets come with split pins to maintain solid contact when mated. Multiple termination options are available.



**16-720
WIRE INSERTION**

**16-722
RING TERMINATION**

**16-724
BULLET TERMINATION**

**16-726
QCS SOCKET**



Zinc Die-Cast *STD PKG: 25*

7-way wire insertion sockets offer a more traditional approach, and are great for dry climates. Zinc die-cast housing options provide added strength and durability.

ISO *STD PKG: 10*

ISO sockets are only available with STA-DRY® housing to prevent corrosion. ISO sockets utilize a female ground pin to avoid connection with a SAE 7-way plug.

**15-720
7-WAY WIRE
INSERTION**



5° Pitch

Single screw disconnect

Offset
insertion
pockets

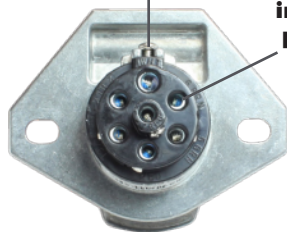

**16-822
ISO - RING
TERMINATION**

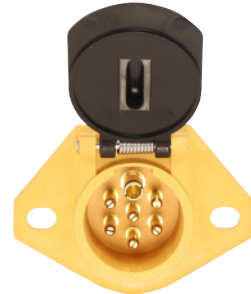

16-824

16-826



SOCKET REPAIR ACCESSORIES

15-724
FITS 15-720
SOCKET
 STD PKG: 25



15-740
SOCKET
BOOT
 STD PKG: 25



15-788
90° MOUNTING
BRACKET
 STD PKG: 5

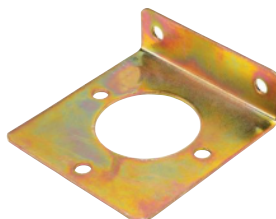

15-798
REPLACEMENT
GASKET
 STD PKG: 10



LID REPLACEMENT KITS STD PKG: 10

16-324
Dual Pole QSC2



15-796
ZINC



16-797
ISO



16-799
STA-DRY®



PREVENTATIVE MAINTENANCE PRACTICES

Routine preventative maintenance should be performed every 3-6 months or sooner to address corrosion. A Phillips 7-way plug and socket brush facilitate easy cleaning.

Note: Once clean and dry, apply dielectric grease to the pins.

4-121
7-WAY PLUG AND
SOCKET BRUSH
 STD PKG: 1

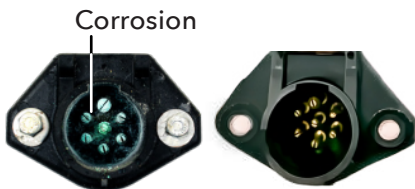

Before

After

80-250
DIELECTRIC GREASE
 STD PKG: 1



7-WAY & ISO PLUGS

Phillips offers 7-way wire insertion repair plugs with zinc and weatherproof options. All plugs come standard with large finger grips for easy coupling/uncoupling, chamfered floating brass pins for secure installation on misaligned sockets, and extended housing that allows for easy cross-over wiring. Meets or exceeds SAE J560 or 3731 specifications.

**15-730
ZINC DIE-CAST**
STD PKG: 25



**15-830
ISO (MALE GROUND)**
STD PKG: 10



**16-730
WEATHER-TITE™**
STD PKG: 25



Our QCP™ cartridges plug-in with no re-wiring required - offering a great solution for pin degradation, when your plug and cable are still in good condition. Our wire insertion cartridges provide thread sealant screws to prevent vibrating loose.

**15-711
FOR 15-730
PLUG INSERT**
STD PKG: 10



**15-715
FOR 16-730
PLUG INSERT**
STD PKG: 10



**16-125
QCP™ CARTRIDGE**
STD PKG: 10



**16-811
FOR 15-830
PLUG INSERT**
STD PKG: 10



**15-731
CABLE GUARD**
STD PKG: 25



J560 PLUG & SOCKET WIRING

7-Way Heavy Duty SAE J560

Phillips sockets and plugs feature color coded wiring - allowing for simple circuit identification during repair or replacement.

WIRING CODE



WHITE - 8GA
GROUND



BLUE - 10GA
AUXILIARY CIRCUIT



GREEN - 12GA
RIGHT TURN



RED - 10GA
STOP LIGHTS AND
ANTI-LOCK DEVICES



BLACK - 12GA
CLEARANCE, I.D.
AND LICENSE



BROWN - 12GA
TAIL LIGHTS, REAR
CLEARANCE AND
MARKER LIGHTS



YELLOW - 12GA
LEFT TURN

FRONT OF SOCKET

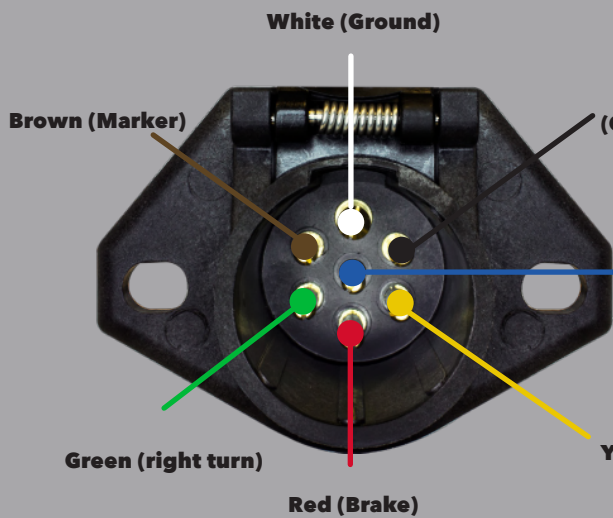

BACK OF SOCKET

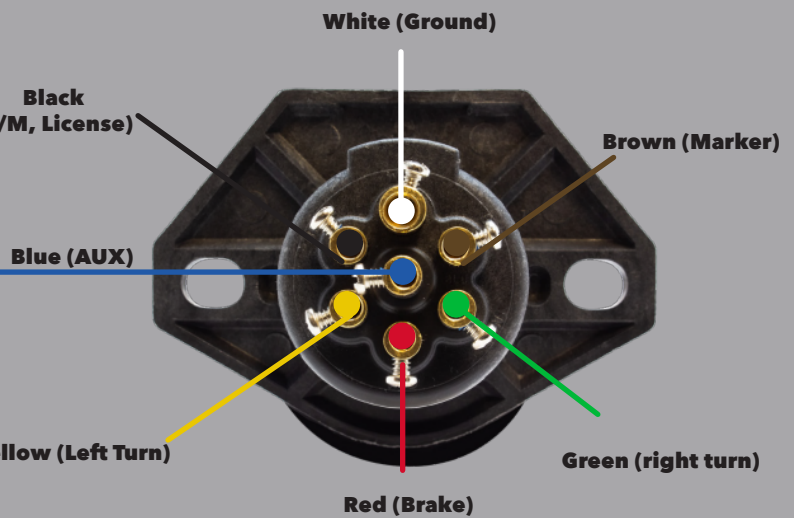

FRONT OF PLUG INSERT

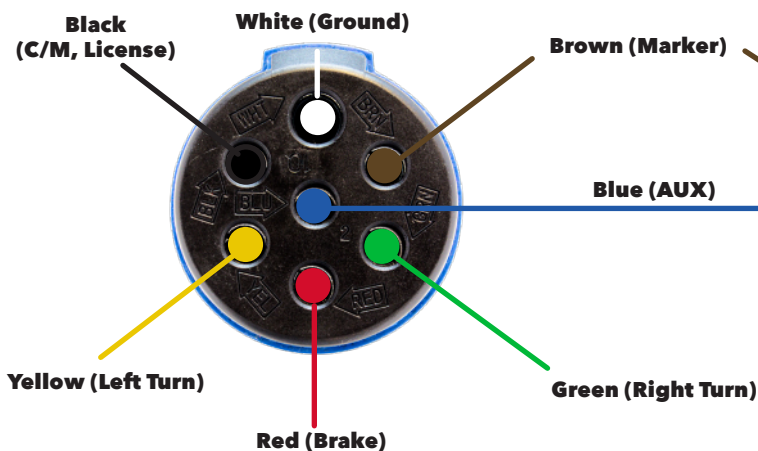

BACK OF PLUG INSERT

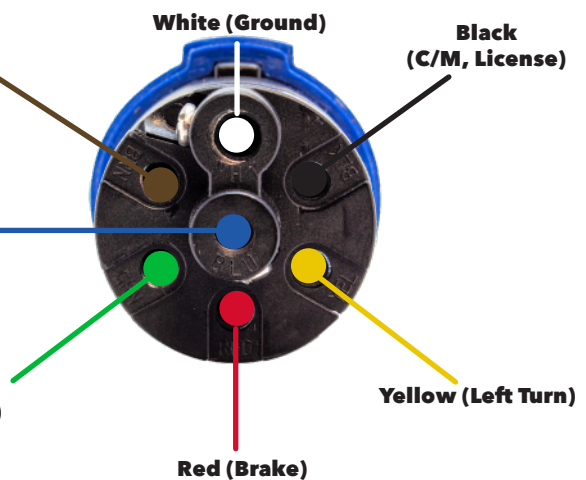

LIFTGATE & TARP SYSTEMS

Our back-of-cab charging systems and connections feature molded plugs and socket housings that are sealed at the back, providing a continuous charge and protection from corrosion.

WEATHER-TITE™ M2

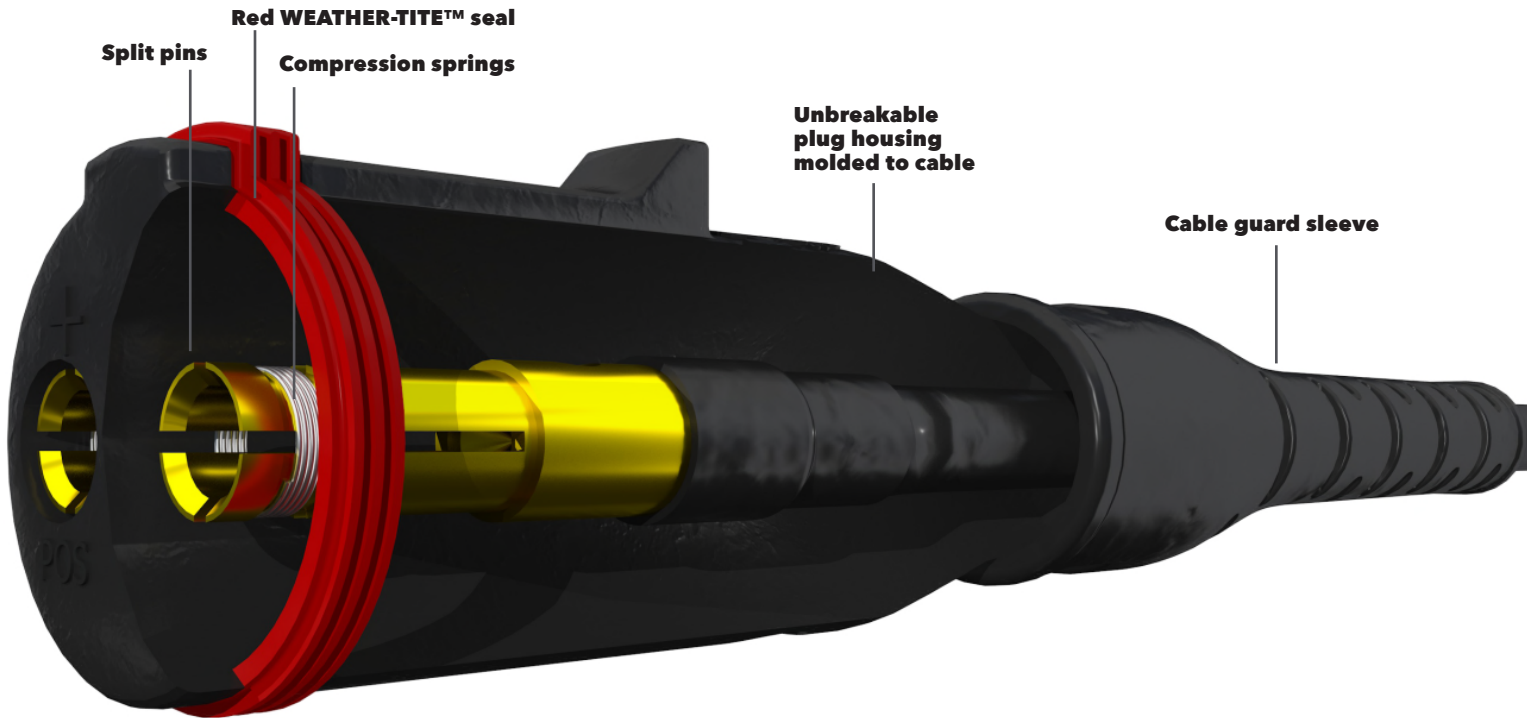

DUAL POLE QCS2®

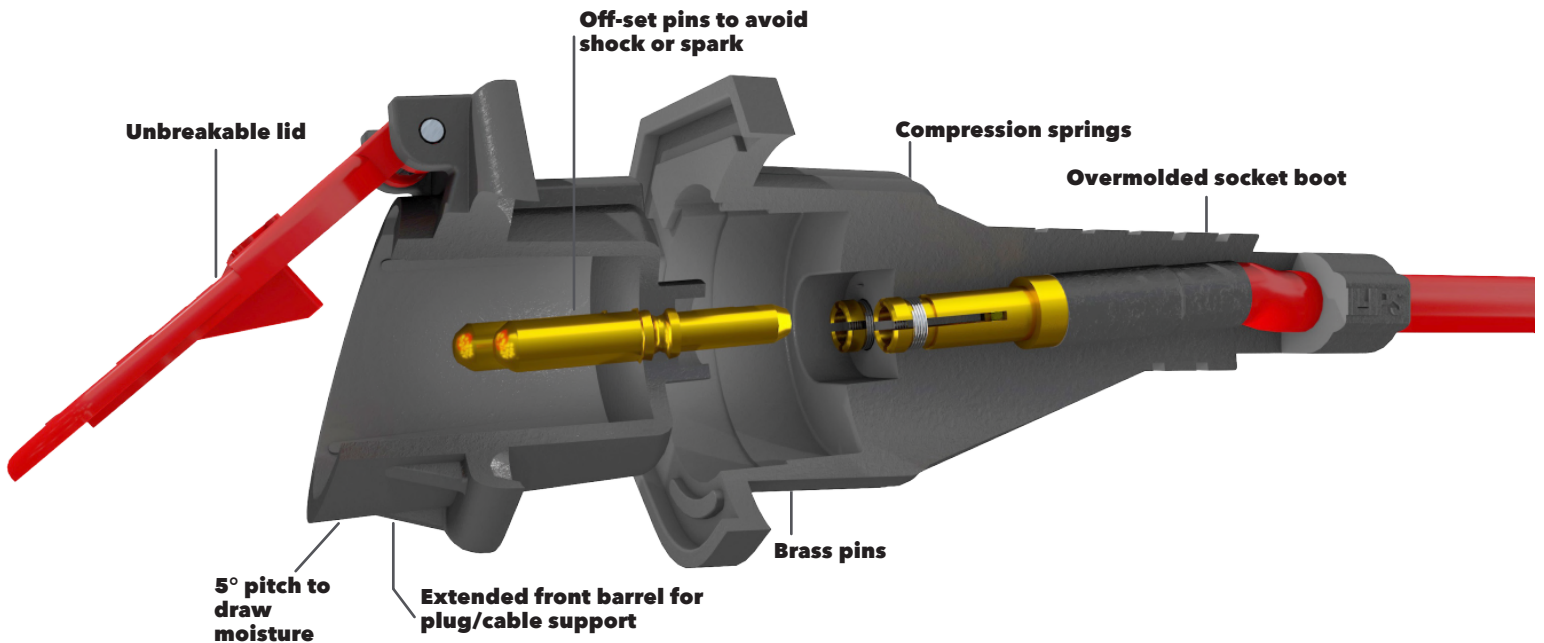

The **ONLY** complete liftgate system

M2 CHARGE KIT

2 GA 25-292769 STD PKG: 1

4 GA 23-292769 STD PKG: 1

The M2 Charge Kit is a back-of-cab charging system that includes a WEATHER-TITE™ M2 cable and tender spring kit for charging cables. It is the ideal solution for fast and easy set-up and best-in-class corrosion prevention for charging systems.



COMPONENTS of M2 CHARGE KIT

20" Tracker Spring Kit for Charging Cables
QWIK-CLAMP™ comes pre-installed on the cable for fast and easy set-up every time

Cable Guard Sleeve
Enhances strain relief protection at the back of the plug for longer cable life

Red WEATHER-TITE™ Seal
Blocks moisture and contaminants from entering the electrical system through the coupled connection

Coiled WEATHER-TITE™ M2 15' with 48" Lead
High performance cable jacketing provides exceptional recoil memory and abrasion resistance

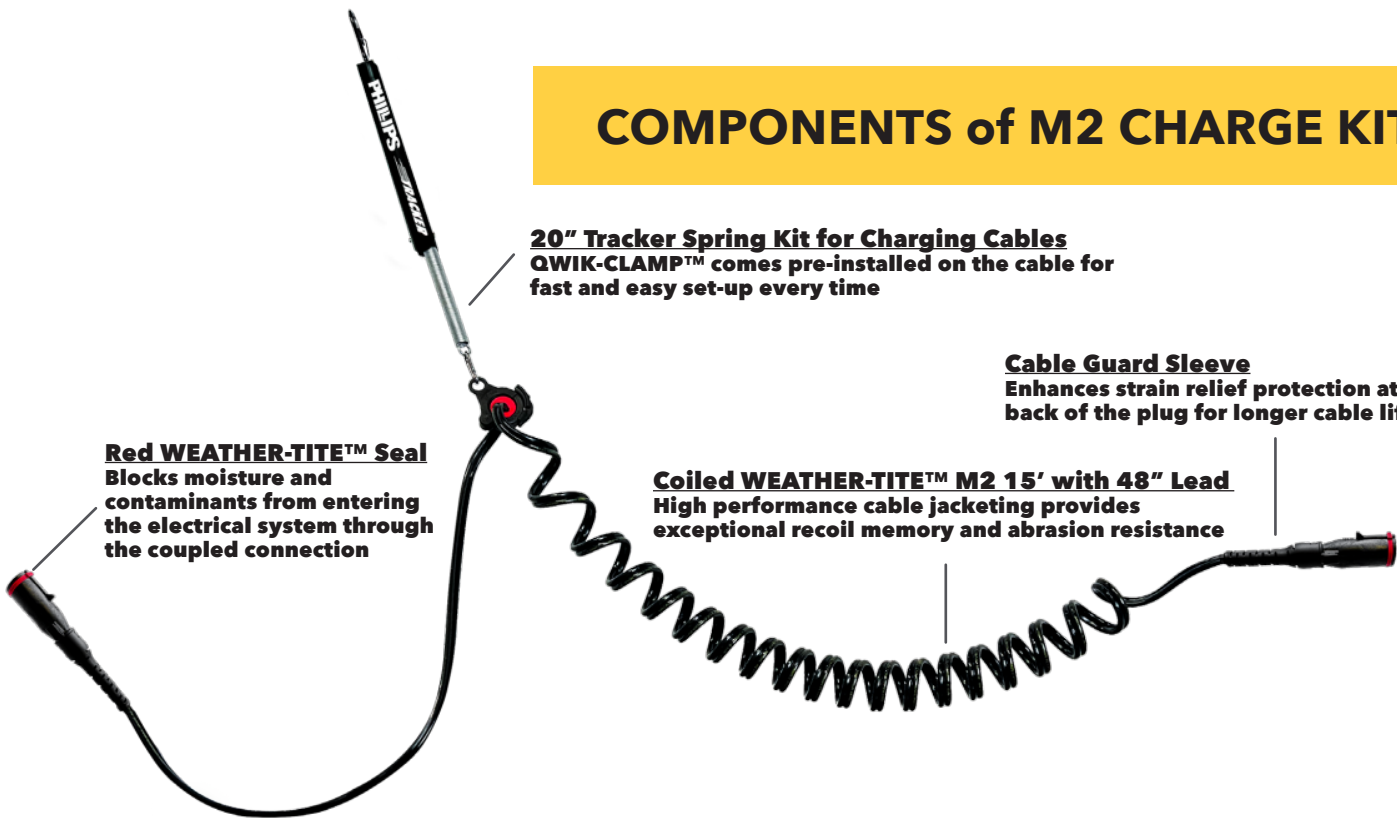

LIFTGATE & TARP SYSTEMS

Charging assemblies support multiple applications such as single pole, dual pole, and single to dual pole. Assemblies are available with zinc die-cast plugs or with weather-proof connectors to help keep corrosion out.

WEATHER-TITE™ M2 STD PKG: 5

Dual pole using molded plugs with WEATHER-TITE™ corrosion prevention rings

2 Ga.







**Dual Pole
Horizontal**

200 Amp Max
150 Amp Continuous



| | COILED | STRAIGHT |
|---------------|----------|----------|
| 12' | 25-23276 | 25-22576 |
| 15' | 25-26276 | 25-22776 |
| 15', 48" LEAD | 25-29276 | - |

 -82°F (-63°C) • 195°F (91°C) -82°F (-63°C) • 195°F (91°C)

EXCELLENT RECOILABILITY

WWWW

WEATHER-TITE™ M2 STD PKG: 5

Dual pole using molded plugs with WEATHER-TITE™ corrosion prevention rings

4 Ga.







**Dual Pole
Horizontal**

200 Amp Max
100 Amp Continuous



| | COILED | STRAIGHT |
|---------------|----------|----------|
| 12' | 23-23276 | 23-22576 |
| 15' | 23-26276 | 23-22776 |
| 15', 48" LEAD | 23-29276 | - |

 -82°F (-63°C) • 195°F (91°C) -82°F (-63°C) • 195°F (91°C)

EXCELLENT RECOILABILITY

WWWW

LIFTGATE & TARP SYSTEMS

Dual Pole Liftgate Cables *STD PKG: 5*

Dual pole with 15-336 heavy-duty zinc die-cast connectors

4 Ga.



Dual Pole Horizontal

200 Amp Max
100 Amp Continuous



| | COILED | STRAIGHT |
|---------------|---------|----------|
| 12' | 23-2326 | 23-2251 |
| 15' | 23-2626 | 23-2271 |
| 15', 48" LEAD | 23-2926 | - |



-82°F (-63°C) • 195°F (91°C)



-82°F (-63°C) • 195°F (91°C)

EXCELLENT RECOILABILITY



Single Pole Liftgate Cables *STD PKG: 5*

Single pole with 15-335 heavy-duty zinc die-cast connectors

4 Ga.



Single Pole

200 Amp Max
100 Amp Continuous



| | COILED | STRAIGHT |
|---------------|---------|----------|
| 12' | 23-4325 | 23-2051 |
| 15' | 23-4625 | 23-2071 |
| 15', 48" LEAD | 23-4925 | - |



-87°F (-63°C) • 150°F (91°C)



-82°F (-63°C) • 195°F (91°C)

GOOD RECOILABILITY



LIFTGATE & TARP SYSTEMS

Dual Pole Tarp Cables STD PKG: 5

Vertical dual pole with 15-338 heavy-duty zinc die-cast connectors

4 Ga.



Dual Pole Vertical

200 Amp Max
100 Amp Continuous



| | PERMACOIL™ | STRAIGHT |
|---------------|------------|----------|
| 12' | 23-4329 | 23-2252 |
| 15' | 23-4629 | 23-2272 |
| 15', 48" LEAD | 23-4929 | - |

-87°F (-63°C) • 150°F (66°C) -82°F (-63°C) • 195°F (91°C)

GOOD RECOILABILITY



WEATHER-TITE™ M2 Dual Pole to Single Pole Zinc Die-Cast STD PKG: 5

Dual pole liftgate with overmolded plug and 3-ring nitrile seal to single pole 15-335

2 Ga.



Dual Pole Horizontal to Single Pole

200 Amp Max
150 Amp Continuous



| | COILED | STRAIGHT |
|-----|---------|----------|
| 12' | 25-2357 | 25-2256 |
| 15' | 25-2657 | 25-2276 |

-82°F (-63°C) • 195°F (91°C) -82°F (-63°C) • 195°F (91°C)

EXCELLENT RECOILABILITY



WEATHER-TITE™ M2 Dual Pole to Single Pole Zinc Die-Cast STD PKG: 5

Dual pole liftgate with overmolded plug and 3-ring nitrile seal to single pole 15-335

4 Ga.



Dual Pole Horizontal to Single Pole

200 Amp Max
100 Amp Continuous



| | COILED | STRAIGHT |
|-----|---------|----------|
| 12' | 23-2357 | 23-2256 |
| 15' | 23-2657 | 23-2276 |

-82°F (-63°C) • 195°F (91°C) -82°F (-63°C) • 195°F (91°C)

EXCELLENT RECOILABILITY



LIFTGATE & TARP SYSTEMS

Dual Pole to Single Pole - Zinc Die-Cast Plugs STD PKG: 5

Single pole 15-335 to dual pole 15-336

4 Ga.



Dual Pole Horizontal to Single Pole

200 Amp Max
100 Amp Continuous



COILED

| | |
|-----|---------|
| 15' | 23-2628 |
|-----|---------|



-82°F (-63°C) • 195°F (91°C)

EXCELLENT RECOILABILITY



Dual Pole "Y" Adapter - Zinc Die-Cast Plugs STD PKG: 5

For fleets with both single and dual pole trailers

4 Ga.



Tractor

Trailer



COILED

| | |
|--|---------|
| 15', 48" tractor-side lead and 24" trailer-side lead | 23-2630 |
|--|---------|



-82°F (-63°C) • 195°F (91°C)

EXCELLENT RECOILABILITY



4-123 Dual Pole Maintenance Kit STD PKG: 1

Prevent avoidable downtime and extend liftgate connector life

Kit Includes:

- Stainless steel pin cleaner for liftgate socket
- Bronze cleaning brush for plug pins
- Stainless steel pin-wear gauge to identify worn out charging connections
- Quick change driver handle switches between brush and pin cleaner
- Sturdy case with instructions inside



LIFTGATE & TARP SYSTEMS

STA-DRY® Dual Pole QCS2® Liftgate Socket Kit - 6 o'clock STD PKG: 1



Includes 16-324 Socket

2 Ga.

16-2223 6 o'clock, 48" cable, includes socket

200 Amp Max
150 Amp Continuous

4 Ga.

16-2423 6 o'clock, 48" cable, includes socket

200 Amp Max
100 Amp Continuous

STA-DRY® Dual Pole QCS2® Liftgate Socket Kit - Straight Back STD PKG: 1



Includes 16-324 Socket

2 Ga.

16-2233 Straight Back, 48" cable, includes socket

200 Amp Max
150 Amp Continuous

4 Ga.

16-2433 Straight Back, 48" cable, includes socket

200 Amp Max
100 Amp Continuous

REPLACEMENT CONNECTORS & KIT

Service Parts

16-324
DUAL POLE QCS2® Socket
STD PKG: 5



15-320
SINGLE POLE
STD PKG: 5

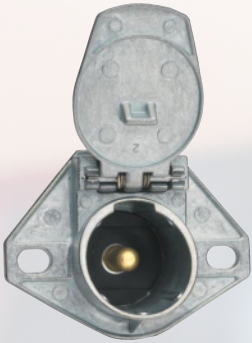

15-326
DUAL POLE
STD PKG: 5



15-328
VERTICAL DUAL POLE
INCLUDES 4 & 6 GA
COPPER LUGS
STD PKG: 5

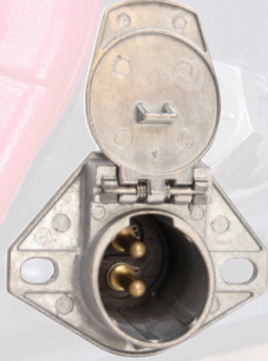

15-335
SINGLE POLE
STD PKG: 5



15-336
DUAL POLE
STD PKG: 5



15-338 - 15-339
4 GA - 6 GA
VERTICAL DUAL POLE
STD PKG: 5



AIR ASSEMBLIES

Prevent brake system failures and potentially serious violations or downtime by protecting air lines. Our POLAR AIR® assemblies feature ultra-protective, ultra-durable jacketing to shield from damage due to abrasions, chemicals and extreme temperatures. They're guaranteed to stay flexible down to -85°F (-65°C). Our heavy-duty rubber air hoses are designed to resist kinking, cracking and bursting, tested to 900 PSI.

RUBBER

POWER GRIP™ XL STD PKG: 5

Extra-large grips with pre-installed gladhands for superior performance



Larger, solid, beefier rubber grips provide kink protection for greater coupling leverage.



Includes corrosion protected anodized gladhands with stainless steel detent plates.



| | PAIR | EMERGENCY | SERVICE |
|-----|-----------|-----------|-----------|
| 12' | 11-831209 | 11-831089 | 11-831169 |
| 15' | 11-831509 | 11-831789 | 11-831869 |

Red & Blue Air Hoses STD PKG: 5

Color-coded for high visibility of service and emergency air lines



| | PAIR | EMERGENCY | SERVICE |
|-----|----------|-----------|----------|
| 12' | 11-81120 | 11-81108 | 11-81116 |
| 15' | 11-81150 | 11-81178 | 11-81186 |

Black Air Hoses with Red & Blue Grips STD PKG: 5

Heavy-duty color coded for ease of identification



| | PAIR | EMERGENCY | SERVICE |
|-----|---------|-----------|---------|
| 12' | 11-8112 | 11-8110 | 11-8111 |
| 15' | 11-8115 | 11-8117 | 11-8118 |

COILED AIR

POLAR AIR® STD PKG: 5
FOR EXTREME CONDITIONS!



SCAN HERE
FOR MORE
INFORMATION

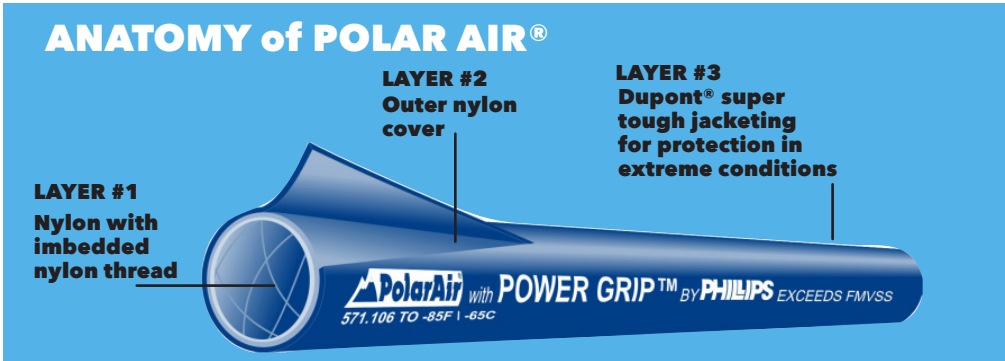

REMAINS FLEXIBLE AT -85°F! 4" Extended Brass Grip, tractor end swivel fitting, thread sealer each end minimum burst pressure 950 PSI, maximum operating pressure 150 PSI, meets or exceeds SAE J 844, J1131

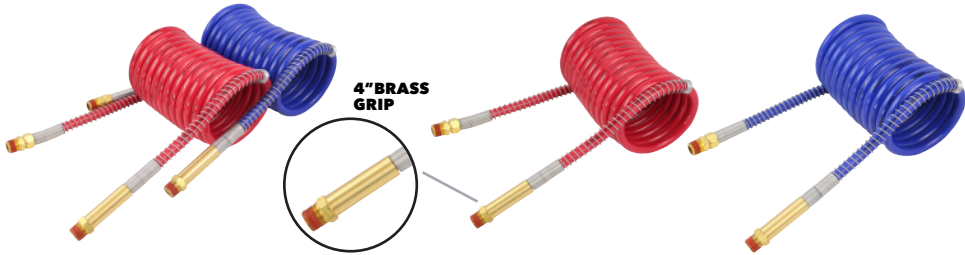

| | PAIR | EMERGENCY | SERVICE |
|---------------|---------|-----------|---------|
| 12' | 11-5120 | 11-5121 | 11-5122 |
| 15' | 11-5150 | 11-5151 | 11-5152 |
| 15', 40" LEAD | 11-5400 | 11-5401 | 11-5402 |

POWER GRIP™ STD PKG: 5

Flexible to -40° F, 4" extended brass grip, tractor end swivel fitting, thread sealer each end, minimum burst pressure 950 PSI, maximum operating pressure 150 PSI, meets or exceeds SAE J844, J1131



| | PAIR | EMERGENCY | SERVICE |
|---------------|---------|-----------|---------|
| 12' | 11-3120 | 11-3100 | 11-3110 |
| 15' | 11-3150 | 11-3170 | 11-3180 |
| 15', 40" LEAD | 11-3400 | 11-3380 | 11-3390 |

AIR ASSEMBLIES

Heavy-Duty Coiled Air STD PKG: 5

Flexible to -40° F, tractor end swivel fitting, thread sealer each end, minimum burst pressure 950 PSI maximum operating pressure 150 PSI, meets or exceeds SAE J 844, J1131



| | PAIR | EMERGENCY | SERVICE |
|---------------|--------|-----------|---------|
| 12' | 11-312 | 11-310 | 11-311 |
| 15' | 11-315 | 11-317 | 11-318 |
| 15', 40" LEAD | 11-340 | 11-338 | 11-339 |

Economy STD PKG: 5

Flexible to -40° F, minimum burst pressure 950 PSI, maximum operating pressure 150 PSI, meets or exceeds SAE J 844, J1131



| | PAIR | EMERGENCY | SERVICE |
|---------------|--------|-----------|---------|
| 12' | 11-712 | - | - |
| 15' | 11-715 | 11-717 | 11-718 |
| 15', 40" LEAD | 11-740 | 11-738 | 11-739 |

Why long leads?

Longer leads connected from the lower cab attachments up through the tracker bar or pogo stick allow for full extension of the coiled cables to help achieve **maximum working length**. Short leads reduce the working length and reduce the assembly's life.

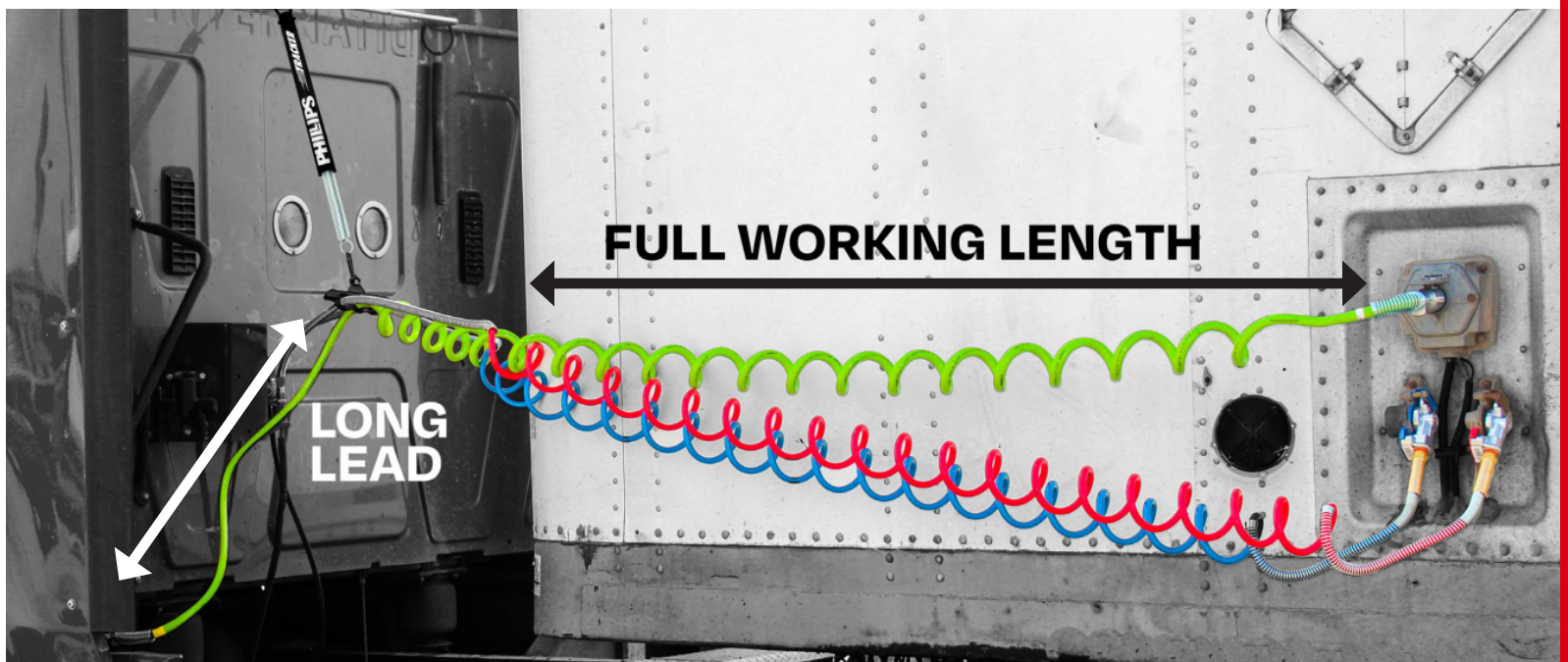
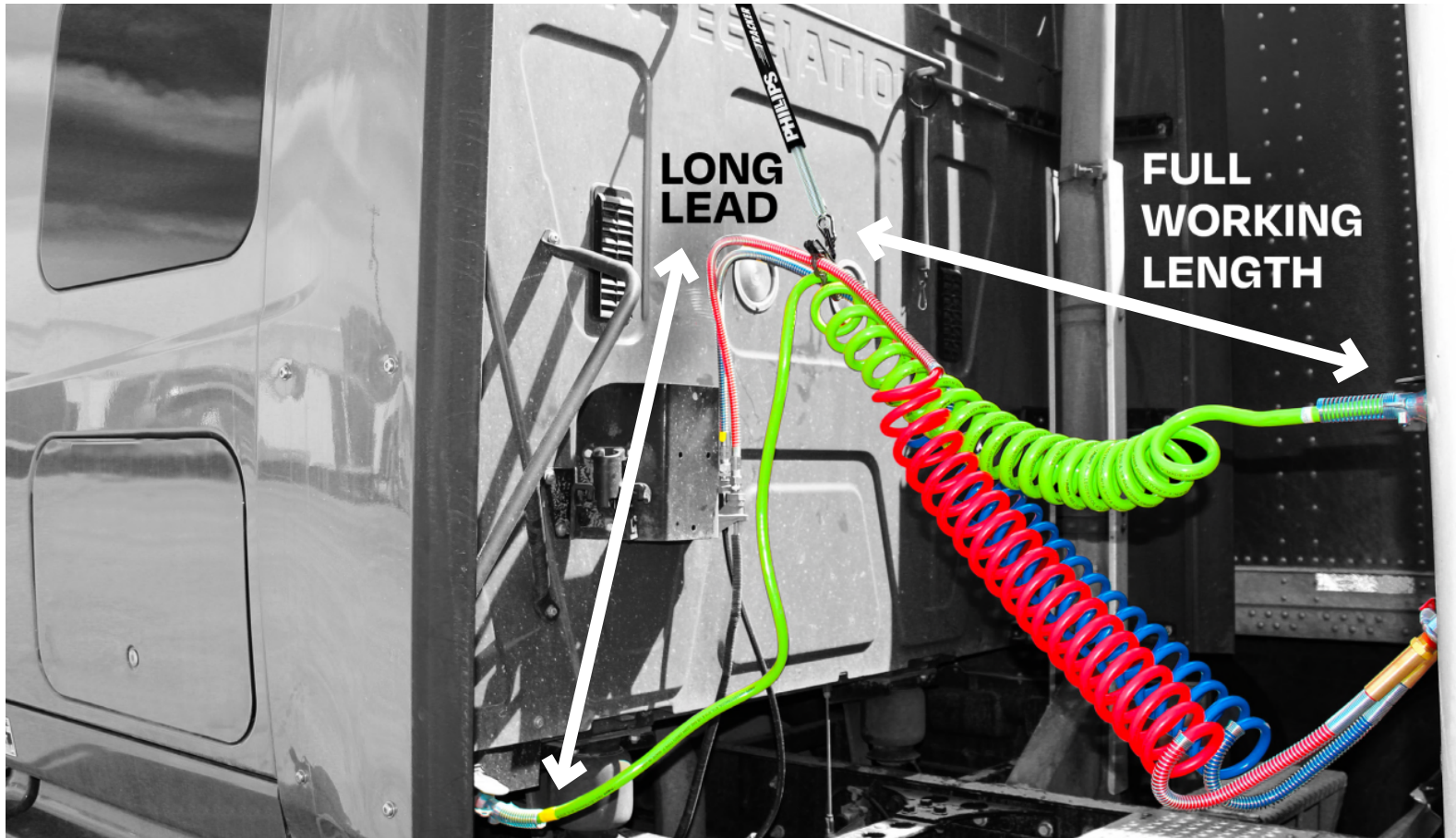

AIR ACCESSORIES

Experience increased air brake system performance with Phillips air accessories and repair items. Get a solid grip on your air lines with gladhand extensions or rubber air grips. Protect brakes and other air-operated systems with the automated and maintenance-free heated electronic drain valve. And be prepared with the QWIK-REPAIR™ rubber air kit for the unexpected while on the road.

12-600
Corrosion Resistance
Extensions
STD PKG: 5 (5 PR)



12-606
Rubber Air Line Grips
SERVICE
STD PKG: 5



12-608
Rubber Air Line Grips
EMERGENCY
STD PKG: 5



12-050 (1/2")
12-052 (3/8")
QWIK-REPAIR™ Kit
STD PKG: 5 PCS



11-8180-250
Bulk Rubber Air
UNIVERSAL
STD PKG: 250 FT



11-8186-250
Bulk Rubber Air
SERVICE
STD PKG: 250 FT



11-8188-250
Bulk Rubber Air
EMERGENCY
STD PKG: 250 FT



12-820
Drain Valve
1/4" Pipe Thread
STD PKG: 5



12-824
Automatic
1/4" Drain Valve
STD PKG: 1



The Phillips Tank Saver Removes harmful moisture & contaminants from air system with a 1 sec. blast every 5 mins. Internal heater for year-round protection.

ALL

- OVER 20% STRONGER than any competitor
- Corrosion resistant powder-coated connector plate
- Zinc-coated detent plate
- E-coated screws for corrosion protection
- Service and emergency keyed to prevent cross coupling
- 1/2" x 1" deep female pipe thread

Phillips gladhand connector plates are 20 to 40% stronger, increasing safety and the life of the gladhand. Anodizing offers another layer of long-life protection



Straight Mount STD PKG: 25

Standard gladhands with aluminum or anodized bodies



| | SERVICE | EMERGENCY | UNIVERSAL |
|--------------------|----------|-----------|-----------|
| Aluminum | 12-006 | 12-008 | 12-010 |
| With filter screen | 12-0061 | 12-0081 | - |
| Anodized Aluminum | 12-00623 | 12-00823 | - |

- Anodizing provides protection from corrosion
- Gladhands with filter screens keep air flow free from debris
- Black rubber seal

Cast Iron STD PKG: 10

Cast iron bodies for extra heavy-duty performance in extreme operating and environmental conditions



| SERVICE | EMERGENCY | UNIVERSAL |
|---------|-----------|-----------|
| 12-406 | 12-408 | 12-410 |

- Spring loaded ball lock
- Extra heavy-duty cast iron
- Integrated connector plate
- Poly seal

GLADHANDS

STA-LOCK™ STD PKG: 5

A combination of aluminum housing and die-cast steel connector plate



| | |
|----------------|------------------|
| SERVICE | EMERGENCY |
| 12-346 | 12-348 |

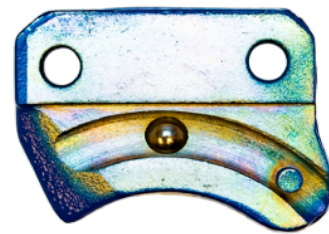

Ball-bearing

Die-cast steel connector plate with spring-loaded ball bearing mounted on aluminum gladhand assists in keeping a strong connection with the mating gladhand.

- Cast iron connector plate
- Stainless steel ball-bearing provides a positive lock for any mating gladhand
- Wide lip seal

LATCH-IT™ STD PKG: 5

Locking gladhand with latching disconnect



| | |
|----------------|------------------|
| SERVICE | EMERGENCY |
| 12-1169 | 12-1189 |



Used in hazardous or rough-road conditions. Prevents accidental disconnections. Requires manual unlatching to disconnect

- Helps prevent accidental disconnect
- Patented latch provides a positive lock
- Stainless steel connector plate and spring for longevity
- Service and emergency powder-coated body for easy identification and corrosion protection

REPLACEMENT SEALS

Polyurethane Seals STD PKG: 25/100

SERVICE



12-0161-25
12-0161-100

EMERGENCY



12-0162-25
12-0162-100

UNIVERSAL



12-0163-25
12-0163-100

Polyurethane Seals with Filter Screen/Dust Flaps STD PKG: 25/100

SERVICE

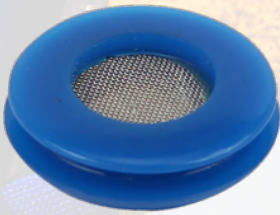

12-01611-25
12-01611-100

EMERGENCY



12-01621-25
12-01621-100

UNIVERSAL



12-01631-25
12-01631-100

**GRAY/UNIVERSAL
with Dust Flaps**



12-0167-25
12-0167-100

Should always be paired
with 12-038



Rubber Seals STD PKG: 25/100

Black, Narrow Lip



12-011-25
12-011-100

**Black, Wide Lip,
Tapered Base**



12-012-25
12-012-100

CABLE SUPPORT

Phillips heavy-duty wire management and stowing systems protect your equipment to prevent CSA violations. Don't let dragging, rubbing, and scraping on the deck plate ruin your electrical and air assemblies. Our wide assortment of support accessories will safeguard and hold your cables in place to save you time and keep you on the road.

Tracker Bar Kits STD PKG: 1



- 17-149** 43" bar, 20" spring
- 17-246** 36" bar, 25" spring
- 17-249** 36" bar, 20" spring

Tracker Bars STD PKG: 1



- 17-147** 43" bar
- 17-247** 36" bar

Spring Kits STD PKG: 5

QWIK-SNAP™

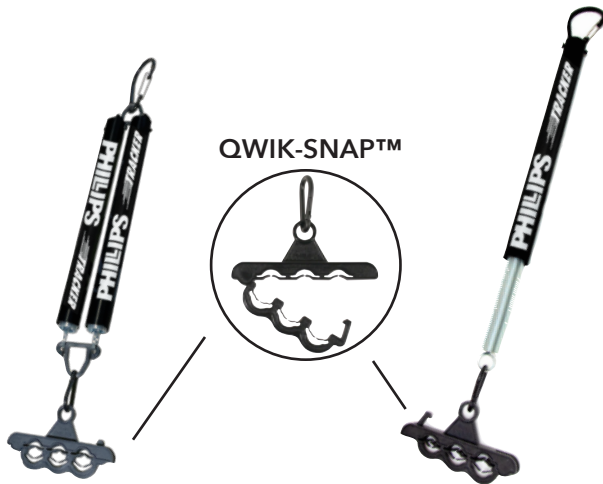

17-420
Dual 16" springs

17-145
25" kit

17-148
20" kit

U-BOLT



17-1487
20" kit

1.5" CLAMP



17-1488
20.5" kit

With 17-180 QWIK-CLAMP™ for Coiled, Straight, and 3-IN-1 Applications

STD PKG: 5



17-1481
20.5" kit

17-1482
25" kit

17-425
Two 16" springs

QWIK-CLAMP™ for Charging Cables STD PKG: 5



17-1484
20" kit

17-1454
25" kit

CABLE SUPPORT

Extends cable attachment an extra 8" from the cab to protect paint and prevent driver noise annoyance. Easy to snap on or move.



X-TEND® STD PKG: 5



17-3000

3/4" Diameter - Freightliner, Navistar, Volvo, & Mack

17-3001

1" Diameter - Kenworth & Peterbilt

X-TEND® Daycab STD PKG: 5



17-3500

3/4" Diameter - Freightliner, Navistar, Volvo, & Mack

17-3501

1" Diameter - Kenworth & Peterbilt

QWIK-SNAP™ STD PKG: 10

Change hoses in seconds! Snaps closed, no tools required! For rubber or nylon airlines.



17-152
2-Hose



17-153
3-Hose



17-154
4-Hose

CABLE SUPPORT

QWIK-CLAMP™ STD PKG: 10

Adaptable *EXTRA* heavy-duty hose clamp with removable insert. Installs in seconds! No tools required!



17-180
For individual air
& electrical cables



17-181
For 3-IN-1s



17-185
For charging cables

U-Bolt & Cable Clamp STD PKG: 10



17-157
3-Hose



17-158
4-Hose



5-5018
For 3-IN-1s
& hydraulic hoses

Pogo Sticks STD PKG: 1

17-0240
24" chrome



17-0241
24" Gold chromate



17-0400
40" chrome



17-0401
40" Gold chromate



CABLE SUPPORT

Replacement Springs *STD PKG: 5*



17-116
16" Spring



17-120
20" Heavy-Duty



17-121
20.5" *EXTRA* Heavy-Duty spring



17-125
25" Heavy-Duty spring

STOW-A-WAY™ *STD PKG: 5*

Easily store plugs and gladhands from the ground. No climbing on the deck plate or leaning over fuel tanks or batteries.



15-041
1 plug,
2 gladhands



15-042
2 plugs,
2 gladhands

Spiral Wrap 1 3/8" Combo Assemblies



5-524
10'
STD PKG: 1

5-536
Bulk 100'
STD PKG: 100'

Tri-Sep



17-174
3-hose separator
STD PKG: 5

Carabiner Clips *STD PKG: 10*



17-161
4" with wire gate



17-163
2.5" Black



17-169
4"
Stainless steel



17-173
2.5"
Stainless steel

Cable Ties *STD PKG: 1*

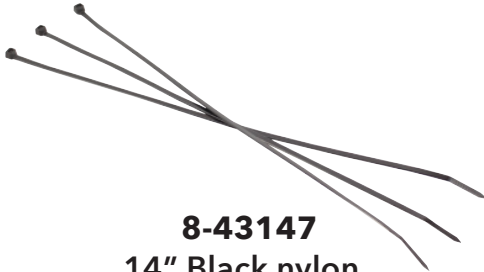

8-43147
14" Black nylon,
50#, Qty 100

MAX bundle diameter: 4"



8-44147
15" Black nylon,
120#, Qty 100

MAX bundle diameter: 4"



8-45134
13" Dual, black nylon,
1/4" mounting hole
150#, Qty 25

MAX bundle diameter:
1 1/4" each side

8-45194
19" Dual, black nylon,
1/4" mounting hole
150#, Qty 25

MAX bundle diameter:
2 1/4" each side



8-61020
Multi-Kit, black

INDEX

| | | | |
|--------------|------|------------------|----|
| 4-121..... | 13 | 11-8115..... | 24 |
| 4-123..... | 21 | 11-8117..... | 24 |
| 5-524..... | 36 | 11-8118..... | 24 |
| 5-536..... | 36 | 11-8180-250..... | 28 |
| 5-5018..... | 7,35 | 11-8186-250..... | 28 |
| 8-43147..... | 37 | 11-8188-250..... | 28 |
| 8-44147..... | 37 | 11-81108..... | 24 |
| 8-45134..... | 37 | 11-81116..... | 24 |
| 8-45194..... | 37 | 11-81120..... | 24 |
| 8-61020..... | 37 | 11-81150..... | 24 |
| 11-310..... | 26 | 11-81178..... | 24 |
| 11-311..... | 26 | 11-81186..... | 24 |
| 11-312..... | 26 | 11-831089..... | 24 |
| 11-315..... | 26 | 11-831169..... | 24 |
| 11-317..... | 26 | 11-831789..... | 24 |
| 11-318..... | 26 | 11-831869..... | 24 |
| 11-338..... | 26 | 11-831209..... | 24 |
| 11-339..... | 26 | 11-831509..... | 24 |
| 11-340..... | 26 | 12-006..... | 29 |
| 11-712..... | 26 | 12-008..... | 29 |
| 11-715..... | 26 | 12-010..... | 29 |
| 11-717..... | 26 | 12-011-25..... | 31 |
| 11-718..... | 26 | 12-011-100..... | 31 |
| 11-738..... | 26 | 12-012-25..... | 31 |
| 11-739..... | 26 | 12-012-100..... | 31 |
| 11-740..... | 26 | 12-038..... | 31 |
| 11-3100..... | 25 | 12-050..... | 28 |
| 11-3110..... | 25 | 12-052..... | 28 |
| 11-3120..... | 25 | 12-346..... | 30 |
| 11-3150..... | 25 | 12-348..... | 30 |
| 11-3170..... | 25 | 12-406..... | 29 |
| 11-3180..... | 25 | 12-408..... | 29 |
| 11-3380..... | 25 | 12-410..... | 29 |
| 11-3390..... | 25 | 12-600..... | 28 |
| 11-3400..... | 25 | 12-606..... | 28 |
| 11-5120..... | 25 | 12-608..... | 28 |
| 11-5121..... | 25 | 12-800..... | 28 |
| 11-5122..... | 25 | 12-801..... | 28 |
| 11-5150..... | 25 | 12-811..... | 28 |
| 11-5151..... | 25 | 12-820..... | 28 |
| 11-5152..... | 25 | 12-824..... | 28 |
| 11-5400..... | 25 | 12-0061..... | 29 |
| 11-5401..... | 25 | 12-0081..... | 29 |
| 11-5402..... | 25 | 12-0161-25..... | 31 |
| 11-8110..... | 24 | 12-0161-100..... | 31 |
| 11-8111..... | 24 | 12-0162-25..... | 31 |
| 11-8112..... | 24 | 12-0162-100..... | 31 |

| | | | |
|--------------------|-------------|-------------------|-------|
| 12-0163-25 | 31 | 16-2233..... | 22 |
| 12-0163-100 | 31 | 16-2423..... | 22 |
| 12-0167-25 | 31 | 16-2433..... | 22 |
| 12-0167-100 | 31 | 16-7403..... | 11 |
| 12-1169..... | 30 | 16-7423-048 | 11 |
| 12-1189..... | 30 | 17-116..... | 36 |
| 12-00623..... | 29 | 17-120..... | 36 |
| 12-00823..... | 29 | 17-121..... | 36 |
| 12-01611-25 | 31 | 17-125..... | 36 |
| 12-01611-100 | 31 | 17-145..... | 32 |
| 12-01621-25 | 31 | 17-147..... | 32 |
| 12-01621-100 | 31 | 17-148..... | 32 |
| 12-01631-25 | 31 | 17-149..... | 32 |
| 12-01631-100 | 31 | 17-152..... | 34 |
| 15-041 | 36 | 17-153..... | 34 |
| 15-042..... | 36 | 17-154..... | 34 |
| 15-320..... | 23 | 17-157..... | 35 |
| 15-326..... | 23 | 17-158..... | 35 |
| 15-328..... | 23 | 17-161..... | 37 |
| 15-335..... | 19,20,22,23 | 17-163..... | 37 |
| 15-336..... | 19,21,23 | 17-169..... | 37 |
| 15-338..... | 20,23 | 17-173..... | 37 |
| 15-339..... | 23 | 17-174..... | 36 |
| 15-711 | 14 | 17-180..... | 33,35 |
| 15-715..... | 14 | 17-181..... | 6,35 |
| 15-720..... | 12 | 17-185..... | 35 |
| 15-724..... | 13 | 17-246..... | 32 |
| 15-730..... | 3,7,10,14 | 17-247..... | 32 |
| 15-731 | 14 | 17-249..... | 32 |
| 15-740..... | 13 | 17-420..... | 32 |
| 15-788..... | 13 | 17-425..... | 33 |
| 15-796..... | 13 | 17-0240..... | 35 |
| 15-798..... | 13 | 17-0241..... | 35 |
| 15-830..... | 10,14 | 17-0400..... | 35 |
| 16-125..... | 2,8,14 | 17-0401..... | 35 |
| 16-324..... | 22,23 | 17-1454..... | 33 |
| 16-720..... | 12 | 17-1481..... | 33 |
| 16-722..... | 12 | 17-1482..... | 33 |
| 16-724..... | 11,12 | 17-1484..... | 33 |
| 16-730..... | 3,7,9,14 | 17-1487..... | 32 |
| 16-797..... | 13 | 17-1488..... | 32 |
| 16-799..... | 13 | 17-3000..... | 34 |
| 16-811..... | 14 | 17-3001..... | 34 |
| 16-824..... | 12 | 17-3500..... | 34 |
| 16-826..... | 12 | 17-3501..... | 34 |
| 16-822..... | 12 | 23-2051..... | 19 |
| 16-2223..... | 22 | 23-2071..... | 19 |

INDEX

| | | | |
|----------------|----|----------------|----|
| 23-2251..... | 19 | 30-2151..... | 7 |
| 23-2252..... | 20 | 30-2154..... | 6 |
| 23-2256..... | 20 | 30-2155..... | 6 |
| 23-2271..... | 19 | 30-2170..... | 7 |
| 23-2272..... | 20 | 30-2171..... | 7 |
| 23-2276..... | 20 | 30-2174..... | 6 |
| 23-2326..... | 19 | 30-2175..... | 6 |
| 23-2626..... | 19 | 30-4320..... | 9 |
| 23-2357..... | 20 | 30-4321..... | 10 |
| 23-2628..... | 21 | 30-4324..... | 8 |
| 23-2630..... | 21 | 30-4327..... | 9 |
| 23-2657..... | 20 | 30-4620..... | 9 |
| 23-2926..... | 19 | 30-4621..... | 10 |
| 23-4329..... | 20 | 30-4624..... | 8 |
| 23-4625..... | 19 | 30-4627..... | 9 |
| 23-4925..... | 19 | 30-4920..... | 9 |
| 23-4629..... | 20 | 30-4921..... | 10 |
| 23-4929..... | 20 | 30-4924..... | 8 |
| 23-22576..... | 18 | 30-4927..... | 9 |
| 23-22776..... | 18 | 30-9320..... | 9 |
| 23-23276..... | 18 | 30-9321..... | 10 |
| 23-26276..... | 18 | 30-9324..... | 8 |
| 23-29276..... | 18 | 30-9334..... | 8 |
| 23-292769..... | 17 | 30-9620..... | 9 |
| 25-2256..... | 20 | 30-9621..... | 10 |
| 25-2276..... | 20 | 30-9624..... | 8 |
| 25-2357..... | 20 | 30-9634..... | 8 |
| 25-2657..... | 20 | 30-9920..... | 9 |
| 25-22576..... | 18 | 30-9921..... | 10 |
| 25-22776..... | 18 | 30-9924..... | 8 |
| 25-23276..... | 18 | 30-9934..... | 8 |
| 25-26276..... | 18 | 30-215429..... | 4 |
| 25-29276..... | 18 | 30-217429..... | 4 |
| 25-292769..... | 17 | 30-245029..... | 5 |
| 30-1157..... | 7 | 30-247029..... | 5 |
| 30-1177..... | 7 | 31-2053..... | 10 |
| 30-2050..... | 9 | 31-2073..... | 10 |
| 30-2051..... | 10 | 31-9323..... | 10 |
| 30-2054..... | 8 | 31-9623..... | 10 |
| 30-2055..... | 8 | 31-9923..... | 10 |
| 30-2057..... | 9 | 80-250..... | 12 |
| 30-2070..... | 9 | | |
| 30-2071..... | 10 | | |
| 30-2074..... | 8 | | |
| 30-2075..... | 8 | | |
| 30-2077..... | 9 | | |
| 30-2150..... | 7 | | |



PHILIPS

WE MAKE PRODUCTS THAT MAKE A DIFFERENCE®

For new and innovative products, visit phillipsind.com

5231 California Ave. Ste. # 220 Irvine CA 92617

800-423-4512